

DEREVE SERIES DF67

STAINLESS STEEL SAFETY RELIEF VALVE - SIDE OUTLET WITH SEALED COVER

The DF67 or 6700 series safety relief valve with side outlet discharge and a sealed top is of stainless steel construction (see below). It is available in 3/8" or 1/2" inlets (standard BSP Taper or NPT). It comes fitted with a Silicone rubber seat as standard but other materials are also available

Specification

The **Series DF67** is a High Lift Safety Relief Valve with sealed top cover and side outlet discharge. The valves are suitable for GAS and LIQUID applications. DF67 is supplied de-greased for oxygen service

The flow is de-rated and measured in accordance with BS EN ISO 4126. The valve re-seats within minus 10% of set pressure.

Pressure range: 0.5 bar G to 12.4 bar G.

Size: 3/8" or 1/2" Inlet both with 1/2" Outlet

Inlets BSPT male taper - Outlets BSP female parallel. NPT inlet optional.

Maximum Set Pressure: 12.4 Bar

Maximum Temperature: 180°C *Depending on seat material*

ALL SAFETY VALVES ARE PED APPROVED AND CE MARKED

Some pressure settings may not always be available—please check with our sales team



Construction

Item	Description	Material
1	Cap	303/304 Stainless
2	Cap Washer	Viton 'O' Ring
3	Adjuster	304 Stainless
4	Tube	304 Stainless
5	Side Outlet	303 Stainless
6	Valve	304 Stainless
7	Valve Pad	Silicone/PTFE/EPDM
8	Base	316 Stainless
9	Spring	302S26 Stainless
10	Ball	316 Stainless
11	Valve Carrier	304 Stainless

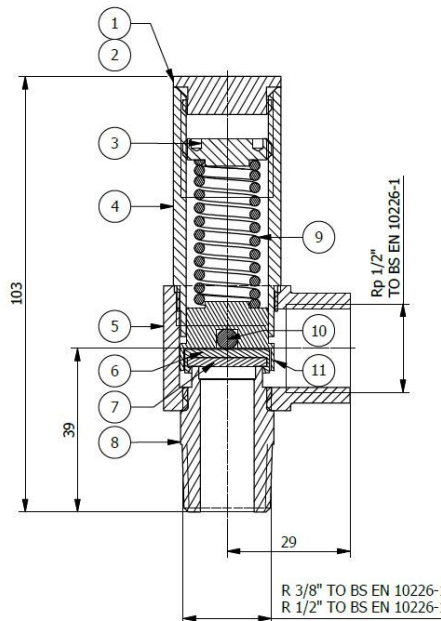

Capacities

AIR @ 15°C in Std. Litres/sec @ 10% overpressure

Size	Bar G	0.5	2.0	5.0	8.0	9.0	11.0
3/8" x 1/2"	L/sec	5	15	36	58	67	84
1/2" x 1/2"	L/sec	19	38	75	112	125	150

Capacities

WATER in Litres per minute @ 10% overpressure

Size	Bar G	0.5	2.0	5.0	8.0	9.0	11.0
3/8" x 1/2"	L/min	4	8	13	17	18	20
1/2" x 1/2"	L/min	8	15	24	31	32	36

* Notional these figures are for guidance only and may vary depending upon system conditions

Whilst every effort has been made to ensure that the information contained in this publication is accurate at the time of publishing, Bonut Engineering Ltd assumes no responsibility or liability for typographical errors or omissions or for any misinterpretation of the information within the publication and reserves the right to change without notice.



BE® Bonut Engineering Ltd

Unit 12 Latham Close, Bredbury Industrial Park
Stockport, Cheshire, SK6 2SD, United Kingdom

Tel: +44 (0) 161 430 4000
Email: sales@bonut.co.uk

Fax: +44 (0) 161 494 1461
Website: www.bonut.co.uk

**DEREVE®
brownall®
RHODES®**