

### DEREVE SERIES DF65HP

SAFETY RELIEF VALVE SIDE OUTLET DISCHARGE COMPLETE WITH SEALED COVER

The DF65HP or 6500 series safety relief valve has a side outlet discharge and a sealed top. This is a high pressure Safety Relief Valve. It is available in 1/2" - 3/4" and comes fitted with a Silicone rubber seat as standard.

#### Features & Benefits

- High performance
- Soft valve washer for 'bubble tight' seal
- Side outlet discharge
- Valve washers to suit air & inert gases
- Brass construction with stainless steel springs
- Pressure range 27.6 barg to 56.8 barg
- Size: 1/2" BSP taper inlet x 3/4" BSP outlet
- Valves can be supplied de-greased for oxygen service & lead wire sealed.

#### Specification

The series DF65 is a High Lift Safety Relief Valve with side outlet discharge suitable for air and inert gas applications.

The flow is de-rated and measured in accordance with BS EN ISO 4126

The valve re-seats by minus 10% of set pressure

- Maximum Set Pressure: 56.8 bar
- Maximum Temperature: 180°C

**ALL SAFETY VALVES ARE PED APPROVED AND CE MARKED**

Valve Size	1/2" x 3/4" (DN15 x DN20)
A	18
B	120
D	45
F	36

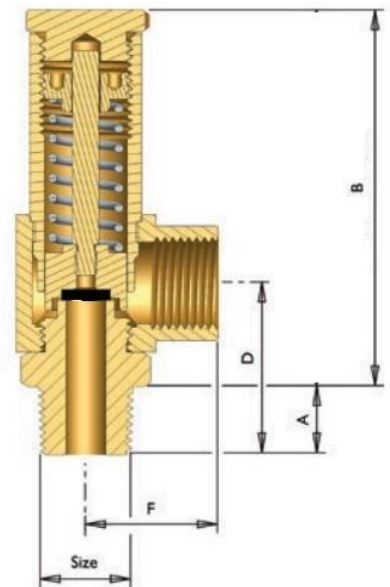

Dimensions in mms

#### Capacities

AIR @ 15°C in Std. Litres/sec @ 10% overpressure

Size	BarG	35.3	43.0	50.7	56.8
1/2" x 3/4"	L/sec	303	367	431	482

\* Notional these figures are for guidance only and may vary depending upon system conditions

Whilst every effort has been made to ensure that the information contained in this publication is accurate at the time of publishing, Bonut Engineering Ltd assumes no responsibility or liability for typographical errors or omissions or for any misinterpretation of the information within the publication and reserves the right to change without notice.



**BE® Bonut Engineering Ltd**

Unit 12 Latham Close, Bredbury Industrial Park  
Stockport, Cheshire, SK6 2SD, United Kingdom  
Tel: +44 (0) 161 430 4000 Fax: +44 (0) 161 494 1461  
Email: sales@bonut.co.uk Website: www.bonut.co.uk

**DEREVE®  
brownall®  
RHODES®**