

#### Fig.933 Straight Through Sight Flow Indicator with Integral Spout - Stainless Steel

This two sided flow indicator features an integral spout that produces a jetting action for turbulent flow thereby improving the viewing of clear liquids.

#### Features & Benefits

- The large viewing area allows the flow, colour and condition of the liquid to be observed, enabling monitoring of product quality and consistency.
- This indicator is suitable for both vertical and horizontal installation. The inclusion of a spout allows for use as a drip indicator to show valve leaks, distillation or similar conditions.
- Available with screwed and flanged end connections, see table below for further detail.



#### Temperature Ratings

Body	Materials		Temperature
	Covers & Bolting	Gaskets	
Stainless Steel	Mild Steel	NRG	-9.5°C to 250°C
	Mild Steel	PTFE	-9.5°C to 200°C
	Stainless Steel	NRG	-150° to 250°C
	Stainless Steel	PTFE	-150° to 200°C

See page 2 for material construction breakdown

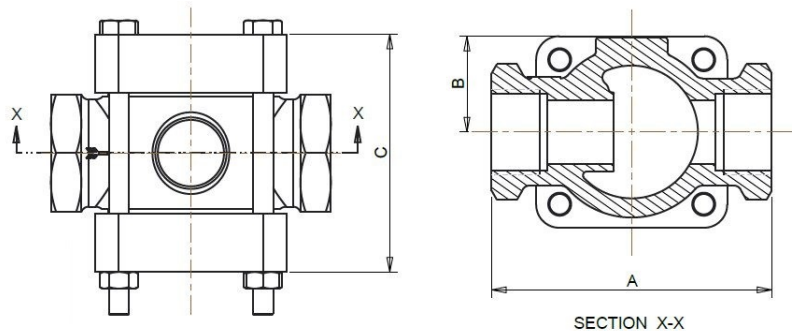

#### Dimensions

SCREWED					FLANGED				
Nominal Bore Size	Length A (mm)	Max Height From Centre B (mm)	Max Width C (mm)	Weight (kg)	Nominal Bore Size	Length A (mm)	Max Height From Centre B (mm)	Max Width C (mm)	Weight (kg)
15	90	30	80	0.9	25	140	38	94	3.5
20	90	30	80	0.9	40	180	45	120	6.5
25	110	38	94	1.7	50	220	56	135	10.5
40	130	45	120	3.1	80	260	86	186	20.5
50	170	56	135	5.8	100	310	94	224	35.5



#### Materials of Construction

Item No.	Description	Body Material	Material	Qty
1	Body	Stainless Steel	ASTM A351 CF8M	1
2	Cover	Mild Steel	BS EN 10025 S355 J2G3	2
		Stainless Steel	304 Stainless Steel	2
3	Glass Disc	Toughened Soda Lime	BS3463	2
		Toughened Borosilicate	DIN 7080	
		Annealed Borosilicate	BS3463	
4	Nut	Mild Steel Zinc Plated/Stainless Steel		4
5	Bolt	Mild Steel Zinc Plated/ Stainless Steel (quantity depends on size)		4
6	Gasket	Nickel Reinforced Graphite / PTFE		4

#### Maximum Ratings

**Full Vacuum to 25 Bar**

Dependent on connection type

#### End Connections

##### Screwed

- BSP Taper 'Rc' BS EN 10226
- BSP Parallel 'Rp' BS EN 10226
- BSP Parallel 'G' ISO 228
- NPT
- Buttweld
- Socket Weld

##### Flanged

- ANSI 150 RF
- ANSI 150 FF
- ANSI 300 RF
- PN16 BS EN 1092
- PN25 BS EN 1092
- Table E BS10
- Table F BS10
- Table H BS10



Certificate Number 9027  
ISO 9001  
ISO 14001

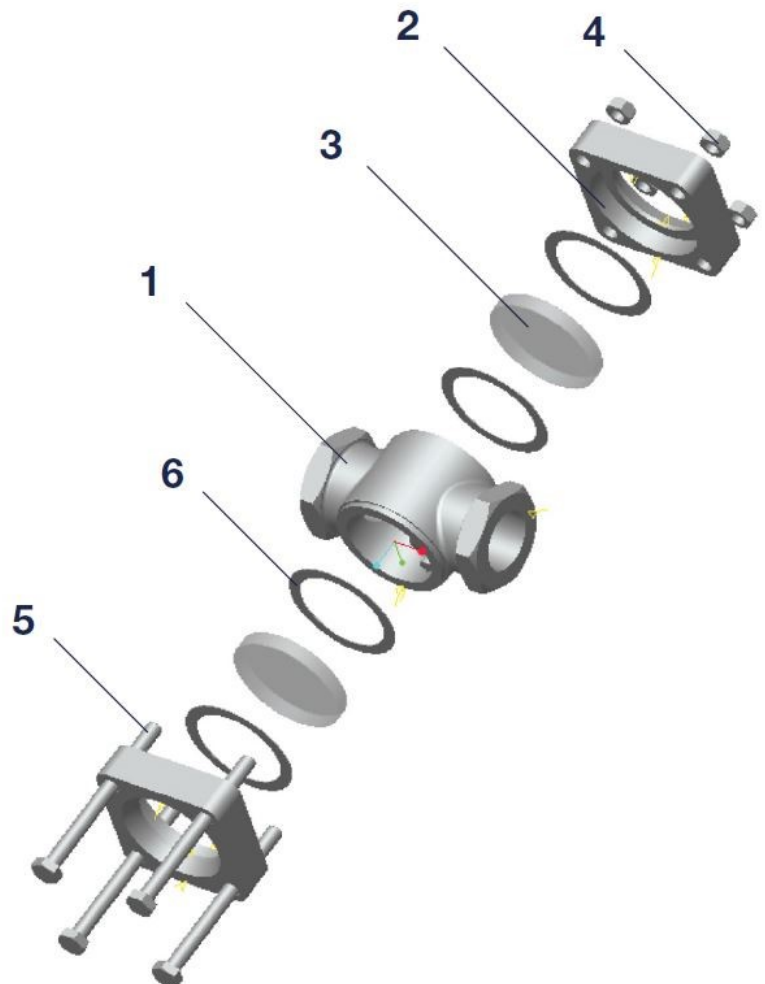

Every effort has been made to ensure that the information contained in this publication is accurate at the time of publishing. Bonut Engineering assumes no responsibility or liability for typographical errors or omissions or for any misinterpretation of the information within the publication and reserves the right to change without notice.



**BE® Bonut Engineering Ltd**

Unit 12 Latham Close, Bredbury Industrial Park  
Stockport, Cheshire, SK6 2SD, United Kingdom

Tel: +44 (0) 161 430 4000  
Email: sales@bonut.co.uk

Fax: +44 (0) 161 494 1461  
Website: www.bonut.co.uk

**DEREVE®  
brownall®  
RHODES®**