

brownall®

Univent 3-Way Vent Valve & 3-Way Vent Cocks

SUPPLIED BY
DELTA FLUID PRODUCTS LTD
DELTA ROAD
ST. HELENS
WA9 2ED
UK
TEL: 01744 611 811
FAX: 01744 453 975

Reasons for using 3-way vent valves or cocks

The use of specially designed 3-way vent valves or cocks on multi-boiler vented hot water heating systems, ensures that there is always a direct connection from the boiler or calorifier to atmosphere, i.e. either to open vent or drain position, enabling maintenance to be carried out on individual boilers.

Principle of operation

Valve: To operate, turn the handwheel clockwise to its full travel to close the drain port and open the vent port. Anti-clockwise operation of the handwheel to its full travel opens the drain port and closes the vent port.

Cock: 90° operation of the level opens and closes vents as shown on the top of the spindle.
N.B. Built-in stop only allows 90° movement.

Installation

On installation of two or more LTHW boilers / calorifiers, the open vent pipe from each boiler / calorifier may be connected into a common vent pipe through a 3-way valve or cock, so arranged that in no circumstances can any boiler / calorifier be isolated simultaneously from the open vent pipe and drain pipe.

Important Note

Valves must not be fitted between the boiler / calorifier and 3-way vent valve or cock and vent pipes shall be continuously rising and unobstructed by a valve or other item.
Connections must be made as marked on 3-way vent valve or cock.

Replacement Cartridge

The replacement cartridge which is available **only** for the Fig. 1688 vent valve allows rapid in-situ servicing for maintenance of the unit.

Technical Details

3-way vent valve

1" – 2 ½" screw down pattern valve

Connections: female BS 21
Body: Gunmetal
Head: Gunmetal
Trim: Brass
Spindle: Brass bar
Renewable seat: EPDM

Max pressure: 7 bar

Max temperature: 93°C

Vent cock

1" – 2" loose lever cock

Connections: female BS 21
Body: Gunmetal
Plug: Gunmetal
Gland: Gunmetal

Max pressure: 7 bar

Max temperature: 93°C

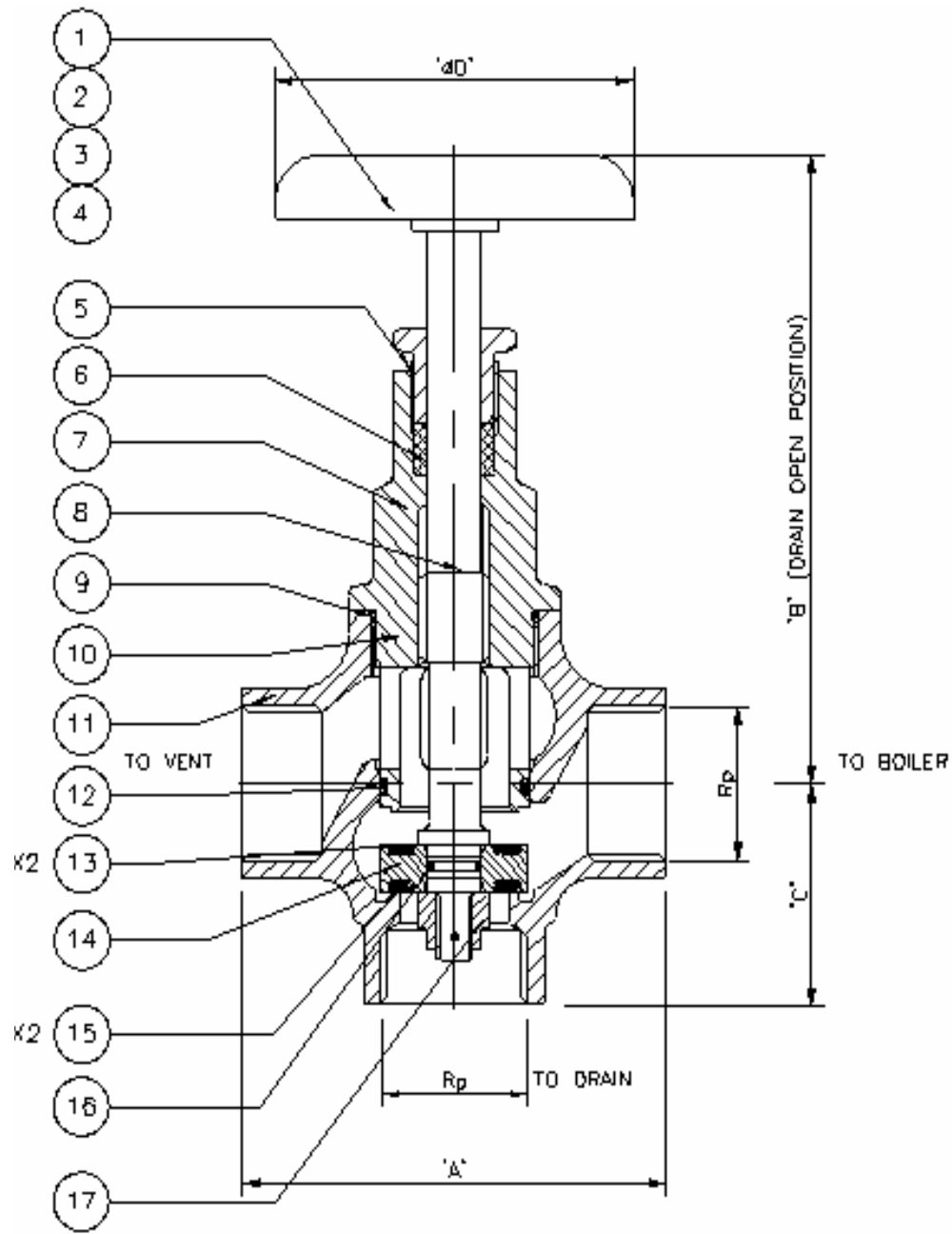
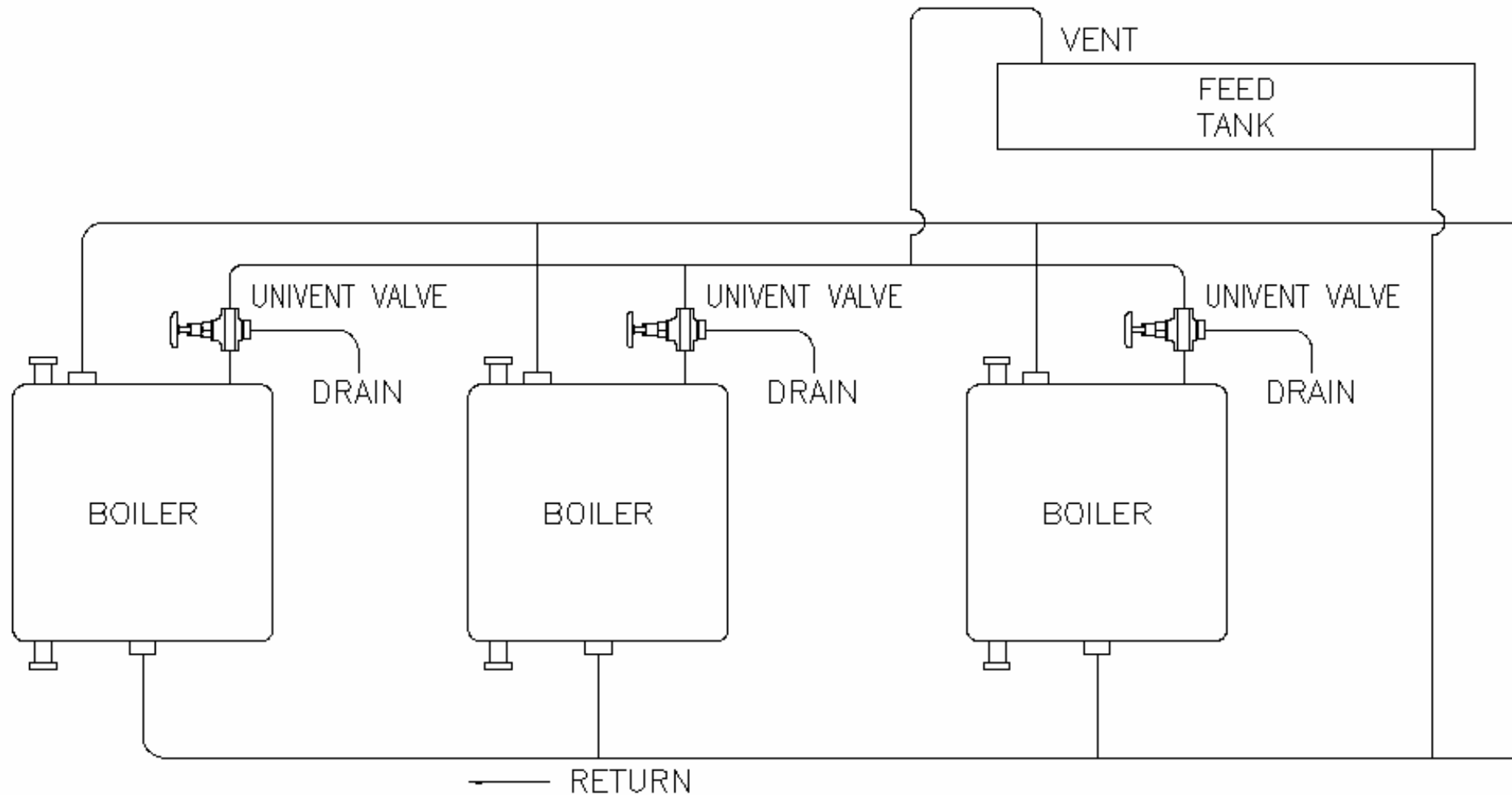

Fig. 1688
Assembly &
Dimensional Details

REF.No	NAME OF PART	MATERIAL
1	HANDWHEEL	ALUMINIUM
2	NAME PLATE	ALUMINIUM
3	HEX HEAD SCREW	BRASS
4	WASHER	BRASS
5	GLAND NUT	BRASS
6	GLAND PACKING	NON ASB. GRAPHITE
7	GLAND RING	BRASS
8	SPINDLE	BRASS
9	'O' RING	VTON RUBBER
10	HEAD	GUNMETAL
11	BODY	GUNMETAL
12	'O' RING	VTON RUBBER
13	RETAINING PLATE(65MM ONLY)	STAINLESS STEEL
14	VALVE DISC	BRASS
15	SEAT INSERT (65MM ONLY)	EPDM RUBBER/MRCIN PTFE(65MM ONLY)
16	'O' RING	VTON RUBBER
17	LOCKNUT	BRASS
18	SPLIT PIN	BRASS

VALVE in	SIZE mm	THREAD	A	B	C	D
1	25	Rp 1	84	145	48	89
1 1/4	32	Rp 1 1/4	98	150	63	102
1 1/2	40	Rp 1 1/2	114	170	72	127
2	50	Rp 2	140	190	78	152
2 1/2	65	Rp 2 1/2	170	220	114	



Note: The diagram shown is schematic and is not intended as a guide to the installation of the vent valves. It is essential that vent valves are fitted in accordance with the manufacturers recommendations and comply with health and safety regulations, etc.

The use of a screw down valve for multi-boiler hot water installations can enable the use of a single vent pipe to serve any number of boilers. No boiler in the system can be left in an unvented condition irrespective of the selected setting of the valves. At all times the vent valve ensures a full bore exit from the boiler to atmosphere.

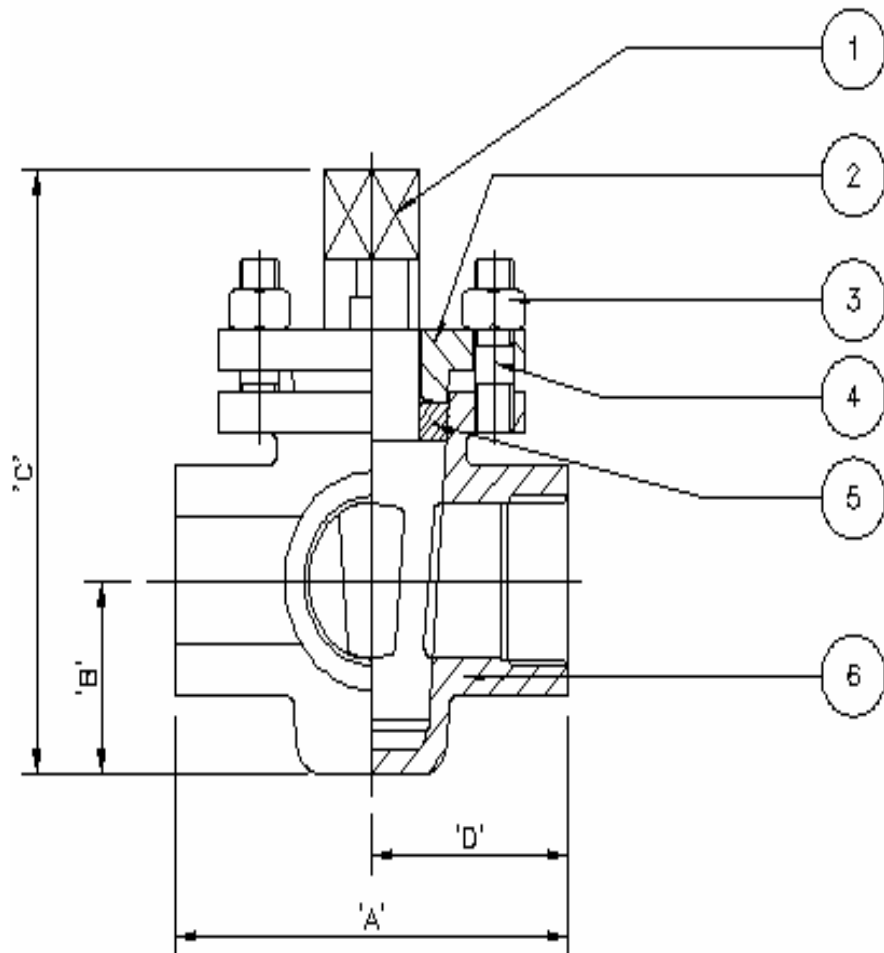

REF.No.	NAME OF PART	MATERIAL
1	PLUG	GUNMETAL
2	GLAND PLATE	GUNMETAL
3	M12 NUT	BRASS
4	M12 STUD	BRASS
5	GLAND PACKING	PILOT PACK NON ASB.
6	VALVE BODY	GUNMETAL

VALVE in	SIZE mm	THREAD	A	B	C	D	E A/F
1	25	Rp 1	90	43	132	45	18
1 ¹ / ₄	32	Rp 1 ¹ / ₄	122	48	155	56	20
1 ¹ / ₂	40	Rp 1 ¹ / ₂	143	57	177	68	25
2	50	Rp 2	165	66	204	80	36

Fig. 1988
Assembly &
Dimensional Details